

Maße

Drehklappe m. Federst.Dichtring

**JAUDT**

NW:  $\varnothing$  350

BH: 130

Geräte Nr.:

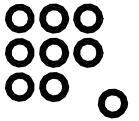

Dimensions

Dimension

Handhebel und Pneumatikzylinder - -

Variante:  
Auslauf mit Rundflansch

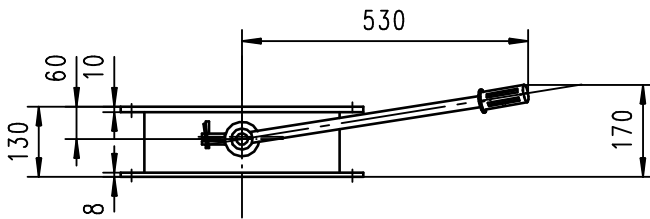

Variante:  
Auslauf mit Eckflansch

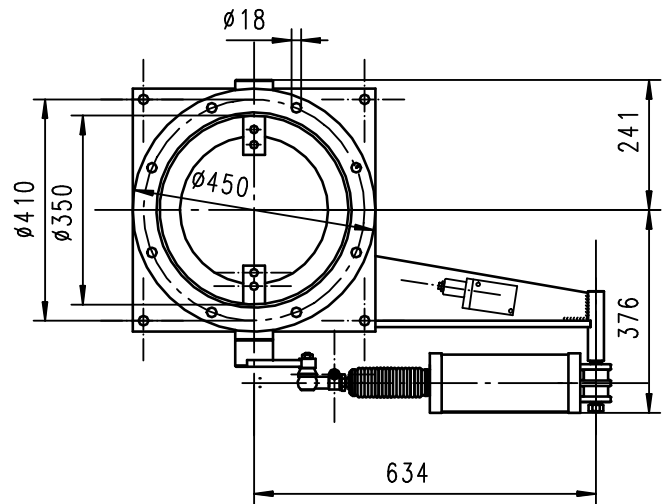
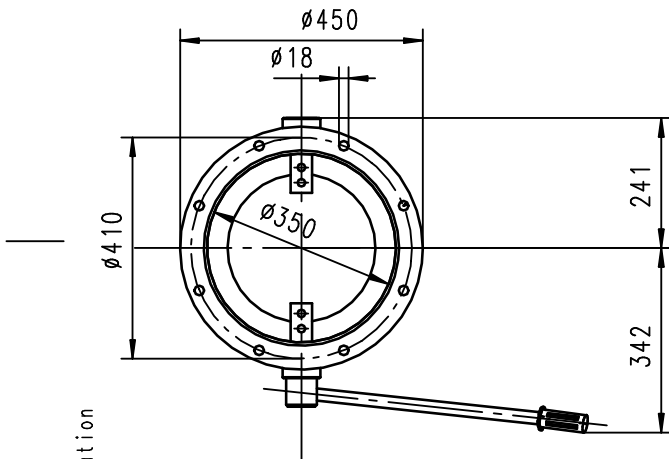
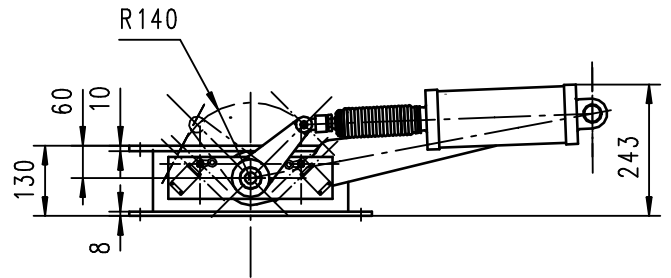

Variante:  
Auslauf mit Wulstring

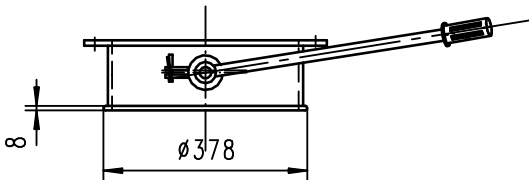

Bohrbild Eckflansch:

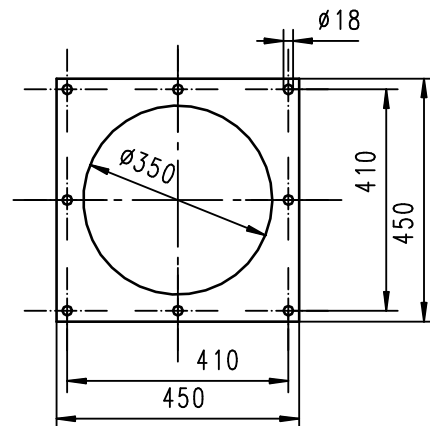

Änderungen vorbehalten / subject to alterations / réserve de modification